

IDROBASE[®]

PASSION FOR WATER



Idrobase Group corporate video



Idrotech by Idrobase Group
Misting Systems at Expo 2015



Misting Book



EN

RESIDENTIAL & COMMERCIAL MISTING

Choose your own customised nebulisation solution to meet your environment refreshing needs

Kit Linea

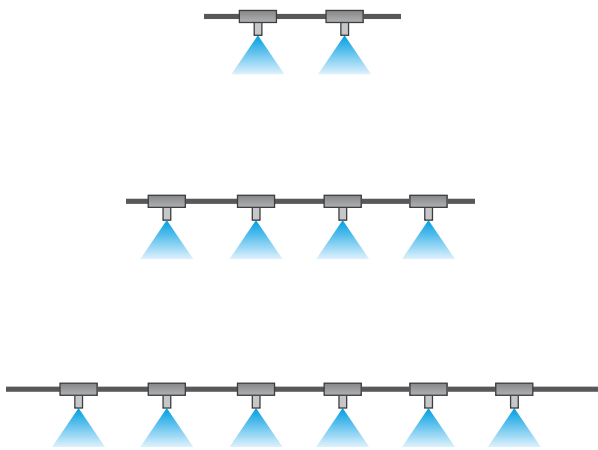

Optimal solution for:

- outdoor gazebos
- verandas
- outdoor walkways
- refreshing systems for outdoor umbrellas
- beach volleyball, futsal/tennis pitches/courts

Kit Vento

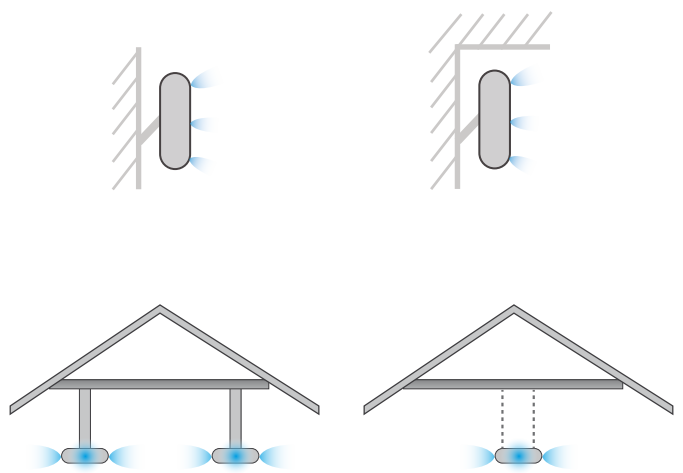

Optimal solution for:

- industrial workshops
- covered outdoor areas of restaurants, bars and bakeries
- parks and gardens
- gyms
- fishmongers' & greengrocers'

Kit Linea



Kit Vento



Linea kit

Choose your line type

Pumping modules

Fog App



Fog Eco Pro



Fog Extra



Code	Description	Coverage in square metres	Fog App		Fog Eco Pro		Fog Extra			
			ZX-FA1.0	ZX-FA1.5	ZX-5095-RC	ZX-5090-RC	ZX-FL-05	ZX-FL-1	ZX-FL-2	
ZX.KL10	Linea kit 10 nozzles	6,75m			•			•		
ZX.KL20	Linea kit 20 nozzles	14,25m	•				•		•	
ZX.KL30	Linea kit 30 nozzles	21,75m		•						•
ZX.KL40	Linea kit 40 nozzles	29,25m								•



Example Linea Kit composition

Linea kit	Description	Linea Kit codes			
		ZX.KL10	ZX.KL20	ZX.KL30	ZX.KL40
	H.p. polyamide pipe ø6.35mm , black, 5m rolls	1pcs	1pcs	1pcs	2pcs
	AISI 304 stainless steel pipe ø6.35mm - 750mm	9pcs	19pcs	29pcs	39pcs
	Straight nozzle holder Slip-Lock quick coupling , in nickel-plated brass, ø6.35mm	9pcs	19pcs	29pcs	39pcs
	End of line nozzle holder Slip-Lock quick coupling , in nickel-plated brass, ø6.35mm	1pcs	1pcs	1pcs	1pcs
	Cleanable fog nozzle in nickel-plated brass , complete with anti-drip valve and 50micron mesh filter, 10/24UNC/2A thread, flow factor 015	10pcs	20pcs	30pcs	40pcs
	Rubberised SS pipe clamp , for polyamide pipe and AISI 304 SS pipe fixing ø6.35mm	16pcs	26pcs	36pcs	51pcs
	Tube cutter for polyamide pipe ø2-12mm	1pcs	1pcs	1pcs	1pcs

Recommended accessory

ZX.KPI	Emergency kit: 2 cleanable fog nozzles in nickel-plated brass, 1 pipe "tee" junction Slip-Lock quick coupling, 1 Slip-Lock line end cap, 2 rubberised stainless steel pipe caps, 1 cap with 10/24UNC/2A thread
---------------	---

Kit Vento

Choose your fan type

	Code	Description	Coverage in square metres	Number of fans	Pumping modules			Fog App		Fog Eco Pro		Fog Extra	
					ZX-FA10	ZX-FA15	ZX-5095-RC	ZX-5090-RC	ZX-FL-05	ZX-FL-1	ZX-FL-2		
	Fan 20"	ZX.KV2-20	Kit 2 Mist Fan 20"	80m ²	2	•		•		•			
		ZX.KV4-20	Kit 4 Mist Fan 20"	160m ²	4	•			•		•		
		ZX.KV6-20	Kit 6 Mist Fan 20"	240m ²	6		•					•	
		ZX.KV8-20	Kit 8 Mist Fan 20"	320m ²	8							•	
	Fan 18"	ZX.KV2-18	Kit 2 Mist Fan 18"	100m ²	2	•		•		•			
		ZX.KV4-18	Kit 4 Mist Fan 18"	200m ²	4	•			•		•		
		ZX.KV6-18	Kit 6 Mist Fan 18"	300m ²	6		•					•	
		ZX.KV8-18	Kit 8 Mist Fan 18"	400m ²	8							•	
	Fan 360°	ZX.KV2-360	Kit 2 Mist Fan 360	60m ²	2	•		•		•			
		ZX.KV4-360	Kit 4 Mist Fan 360	120m ²	4	•			•		•		
		ZX.KV6-360	Kit 6 Mist Fan 360	180m ²	6		•					•	
		ZX.KV8-360	Kit 8 Mist Fan 360	480m ²	8							•	
	Fan Panorama	ZX.KV2-P	Kit 2 Fan 360 Panorama	100m ²	2	•			•		•		
		ZX.KV4-P	Kit 4 Fan 360 Panorama	200m ²	4		•					•	

Pumping modules



Fog Eco Pro



Fog Extra



KIT MIST FAN 20"

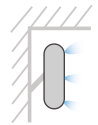

Example Vento Kit Composition

Vento kit	Description	ZX-KV2-20	ZX-KV4-20	ZX-KV6-20	ZX-KV8-20
	Mist Fan 20" - 51.5cm 3 speeds, 90° swinging, complete with a wall mounting bracket, white colour, power cable length 2.2m. Air flow rate 2940m ³ /h, 74W, 230V-50Hz. Coverage 40m ²	2pcs	4pcs	6pcs	8pcs
	AISI 304 stainless steel nozzle holder ring , 6 holes, 10/24UNC/2A thread for Mist Fan 18", Slip-Lock inlet ø6.35mm	2pcs	4pcs	6pcs	8pcs
	Fog nozzle in nickel-plated brass , complete with anti-drip valve and cleanable 50micron mesh filter, 10/24UNC/2A thread, flow factor 015	12pcs	24pcs	36pcs	48pcs
	Nickel-plated brass cap 10/24UNC/2A thread	4pcs	8pcs	12pcs	16pcs
	"Tee" pipe junction Slip-Lock quick coupling , in nickel-plated brass, ø6.35mm	1pcs	3pcs	5pcs	7pcs
	H.p. polyamide pipe ø6.35mm , rolls of 25m, white	1pcs	2pcs	3pcs	4pcs
	Tube cutter for polyamide pipe ø2-12mm	1pcs	1pcs	1pcs	1pcs
	Rubberised stainless steel pipe clamp , for polyamide pipe fixing ø6.35mm	20pcs	40pcs	60pcs	80pcs









Recommended accessory

ZX.KPI	Emergency kit: 2 cleanable fog nozzles in nickel-plated brass, 1 pipe "tee" junction Slip-Lock quick coupling, 1 Slip-Lock line end cap, 2 rubberised stainless steel pipe caps, 1 cap with 10/24UNC/2A thread
---------------	---

KIT MIST FAN 18"



Example Vento Kit Composition

Vento kit	Description	ZX-KV2-18	ZX-KV4-18	ZX-KV6-18	ZX-KV8-18
	Mist Fan 18" - 46cm axial, 3 speeds, pre-set for mounting on wall, swinging 90°, colour white, length of power cable 2.2m. Air flow rate 9000m ³ /h, 125W, 230V-50Hz. Coverage 50m ²	2pcs	4pcs	6pcs	8pcs
	Wall mounting bracket for Mist Fan 18"	2pcs	4pcs	6pcs	8pcs
	AISI 304 stainless steel nozzle holder ring , 6 holes, 10/24UNC/2A thread for Mist Fan 18", Slip-Lock inlet ø6.35mm	2pcs	4pcs	6pcs	8pcs
	Fog nozzle in nickel-plated brass , complete with anti-drip valve and cleanable 50micron mesh filter, 10/24UNC/2A thread, flow factor 015	12pcs	24pcs	36pcs	48pcs
	Nickel-plated brass cap 10/24UNC/2A thread	4pcs	8pcs	12pcs	16pcs
	"Tee" pipe junction Slip-Lock quick coupling , in nickel-plated brass, ø6.35mm	1pcs	3pcs	5pcs	7pcs
	H.p. polyamide pipe ø6.35mm , rolls of 25m, white	1pcs	2pcs	3pcs	4pcs
	Tube cutter for polyamide pipe ø2-12mm	1pcs	1pcs	1pcs	1pcs
	Rubberised stainless steel pipe clamp , for polyamide pipe fixing ø6.35mm	20pcs	40pcs	60pcs	80pcs

Recommended accessory

ZX.KPI Emergency kit: 2 cleanable fog nozzles in nickel-plated brass, 1 pipe "tee" junction Slip-Lock quick coupling, 1 Slip-Lock line end cap, 2 rubberised stainless steel pipe caps, 1 cap with 10/24UNC/2A thread

KIT MIST FAN 360°



Example Vento Kit Composition

Vento kit	Description	ZXXV2-360	ZXXV4-360	ZXXV6-360	ZXXV8-360
	Mist Fan 360° - single speed, complete with ceiling mounting bracket, holder ring for 6 nozzles, colour white. Air flow rate 4,020m ³ /h, 97W, 230V-50Hz. Coverage 30m ²	2pcs	4pcs	6pcs	8pcs
	Fog nozzle in nickel-plated brass , complete with anti-drip valve and cleanable 50micron mesh filter, 10/24UNC/2A thread, flow factor 015	12pcs	24pcs	36pcs	48pcs
	"Tee" pipe junction Slip-Lock quick coupling , in nickel-plated brass, ø6.35mm	1pcs	3pcs	5pcs	7pcs
	H.p. polyamide pipe ø6.35mm , rolls of 25m, white	1pcs	2pcs	3pcs	4pcs
	Tube cutter for polyamide pipe ø2-12mm	1pcs	1pcs	1pcs	1pcs
	Rubberised stainless steel pipe clamp , for polyamide pipe fixing ø6.35mm	20pcs	40pcs	60pcs	80pcs

Recommended accessory

ZX.KPI	Emergency kit: 2 cleanable fog nozzles in nickel-plated brass, 1 pipe "tee" junction Slip-Lock quick coupling, 1 Slip-Lock line end cap, 2 rubberised stainless steel pipe caps, 1 cap with 10/24UNC/2A thread
---------------	---



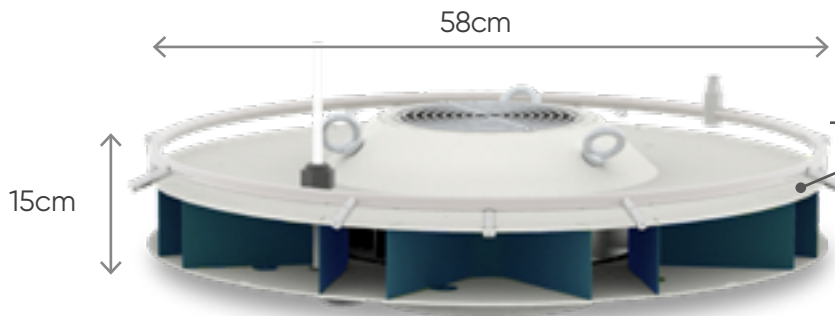
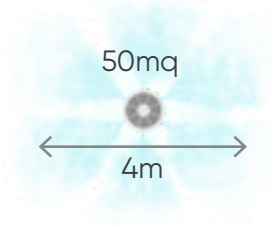
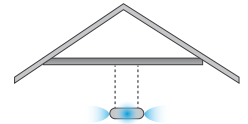

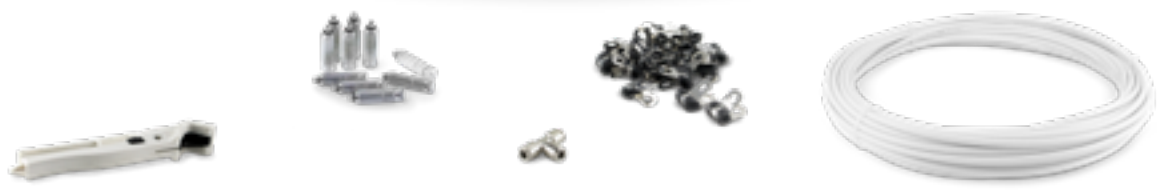

KIT FAN 360° PANORAMA



For covered areas



Example Vento Kit Composition

Vento kit	Description	ZX.KV2-P	ZX.KV4-P
	Fan 360° Panorama. Single speed, pre-set for ceiling mounting, complete with holder ring for 8 nozzles, colour white, air flow rate 600m ³ /h, 100W, 230V-50Hz. Coverage 50m ²	2pcs	4pcs
	Fog nozzle in nickel-plated brass, complete with anti-drip valve and cleanable 50micron mesh filter, 10/24UNC/2A thread, flow factor 015	16pcs	24pcs
	"Tee" pipe junction Slip-Lock quick coupling, in nickel-plated brass, ø6.35mm	1pcs	3pcs
	H.p. polyamide pipe ø6.35mm, rolls of 25m, white	1pcs	2pcs
	Tube cutter for polyamide pipe ø2-12mm	1pcs	1pcs
	Rubberised stainless steel pipe clamp, for polyamide pipe fixing ø6.35mm	20pcs	40pcs

Recommended accessory

ZX.KPI

Emergency kit: 2 cleanable fog nozzles in nickel-plated brass, 1 pipe "tee" junction Slip-Lock quick coupling, 1 Slip-Lock line end cap, 2 rubberised stainless steel pipe caps, 1 cap with 10/24UNC/2A thread



Fog module 60bar
230V-50Hz

Percorso Efficienza  Innovazione
Percorso efficienza
Innovazione



Fog App: the new solution for refreshing outdoor areas via smartphones



Water inlet filter as standard, with 80micron AISI 304 stainless steel mesh. Works in conjunction with IT.0581 water supply Kit

Simple and effective

Fog App is the smartest solution to **refresh** bars, restaurants, patios in small and medium-sized areas. The system can be connected to both ventilation and in-line cooling systems and can be **controlled** conveniently **from the application via a smartphone**.



Silent working



Considerably reduces the temperature



Keeps mosquitoes away



Simple mode to select:
- operation time:
- up to max 4 time slots
- work/pause time:
with min work time of 3s and min pause time of 15s



Advanced mode to select:
- operation time:
time slots as required
- work/pause time: customised for each time slot with min work time of 3s and min pause time of 15s



Slip-Lock connectors for water inlet ø9.6mm and water outlet ø6.35mm

Tech. features

Code	Model	*No. of nozzles 50Hz	Pressure	Flow rate 50Hz	Power absorption	Weight
ZX.FA1.0	FOG APP 1	20	60bar	1l/min	180W (230V-50Hz)	10kg
ZX.FA1.5	FOG APP 1,5	30	60bar	1,5l/min	180W (230V-50Hz)	10kg



* The max number of nozzles has been calculated by using a nozzle with flow rate factor 015 (0.047l/min) at 60bar

FOG APP is compatible with:

Linea kit ZX.KL20 and ZX.KL30

Kit Vento ZX.KV4-20, ZX.KV6-20, ZX.KV2-18, ZX.KV4-18, ZX.KV6-18, ZX.KV2-360, ZX.KV4-360, ZX.KV6-360, ZX.KV2-P and ZX.KV4-P

Recommended accessories

	IT.0581	Water supply kit complete with mesh filter, and Fog module 3m water connection pipe		ZX.0561	Pressure gauge kit in AISI 304 stainless steel, ø40mm, 1/4" M-F, 0-160bar
	IT.0582	Anti-limescale filter with polyphosphate salts for water supply kit			

Fog App control panel

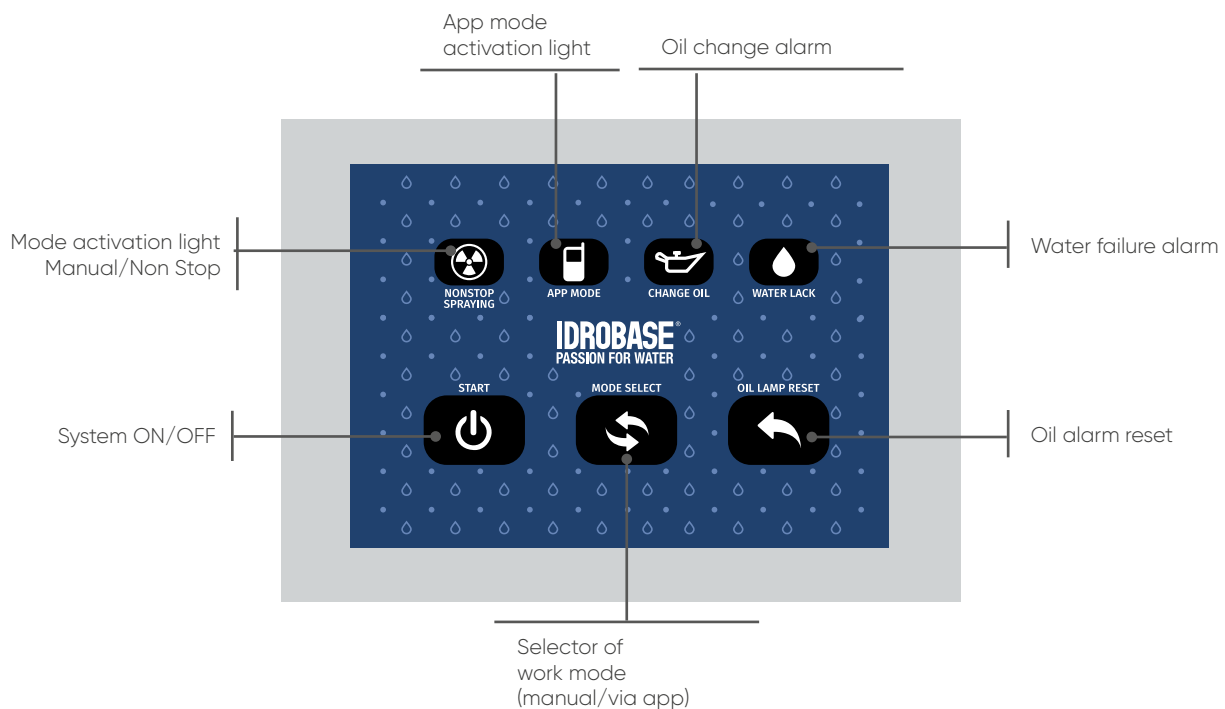

Technical features

- **Frame** made of galvanised painted plate
- **Electric pump** 3 pistons, axial, with brass head
- **Thermal protection** against current surge
- **Unloader valve**
- **LP pressure switch** due to lack of water
- **Solenoid valve** l.p. water inlet
- **Solenoid valve** h.p. for pressure discharge
- **Inlet, Slip-Lock** ø9.6mm
- **Outlet, Slip-Lock** ø6.35mm
- **Instrument panel with 3 touch buttons** for:
 - machine ON/OFF
 - Manual mode selection or Bluetooth activation for smartphone control
 - Alarms reset for maintenance
- **Possibility to manage 3 different modes via the app:**
 - **Nonstop:** the Fog module works in continuous mode
 - **Simple mode:** selection of days of the week, selection of max 4 time slots, work/pause time selection with min 3s work time and min 15s pause time
 - **Advanced mode:** selection of the days of the week, selection of max 20 time slots, selection of work/pause times customised for each time slot with min 3s work time and min 15s pause time
- **Dimensions WxLxH:** 415 x 250 x 215mm

FOG Eco Pro

Fog module 60bar
230V-50Hz



Water inlet filter as standard, with 80micron AISI 304 stainless steel mesh. Works in conjunction with IT.0581 water supply Kit

Compact and versatile

The most **compact** and **versatile** solution for cooling, creating fog effects and humidifying small and medium sized areas. Wide variety of **accessories** and types of line **matchable as required** for use in a wide range of applications.



Considerably reduces the temperature



No wet



Keeps mosquitoes away



Silent working



Slip-Lock connectors for water inlet $\varnothing 9.6\text{mm}$ and water outlet $\varnothing 6.35\text{mm}$



Timing of pause/work pre-settings:
- T1 15" ON - 10" OFF
- T2 20" ON - 15" OFF
- T3 20" ON - 30" OFF



Radio control range 15m with 4 channels:
- ON/OFF pump
- ON/OFF lights
- ON/OFF fans
- ON/OFF pump and fans

Tech. features







Code	Model	*Nozzles n°	Pressure	Flow rate	Power absorption	Weight
ZX.5095-RC	FOG ECO PRO 05	10	60bar	0,5l/min	125W (1x230V-50Hz)	15kg
ZX.5090-RC	FOG ECO PRO 1	20	60bar	1l/min	200W (1x230V-50Hz)	15kg

* The max number of nozzles has been calculated by using a nozzle with flow rate factor 15 (0.047l/min) at 60bar

FOG ECO PRO is compatible with:

Linea kit	ZX.KL10 and ZX.KL20
Kit Vento	ZX.KV2-20, ZX.KV4-20, ZX.KV2-18, ZX.KV4-18, ZX.KV2-360, ZX.KV4-360, and ZX.KV2-P

Recommended accessories

	IT.0581	Water supply kit complete with mesh filter, and Fog module 3m water connection pipe		IT.0269-20	Temperature probe for remote control IT.0104, 20m cable
	IT.0582	Anti-limescale filter with polyphosphate salts for water supply kit		IT.0105	Humidistat remote control , ideal for controlling and maintaining the desired humidity level in an environment
	ZX.0561	Pressure gauge kit in AISI 304 stainless steel, ø63mm, 1/4" M, 0-160bar		IT.0137-20	Humidity probe for remote control IT.0105, with 20m cable
	IT.0104	Thermostat remote control , complete with temperaturesensing probe			

Fog Eco Pro controls

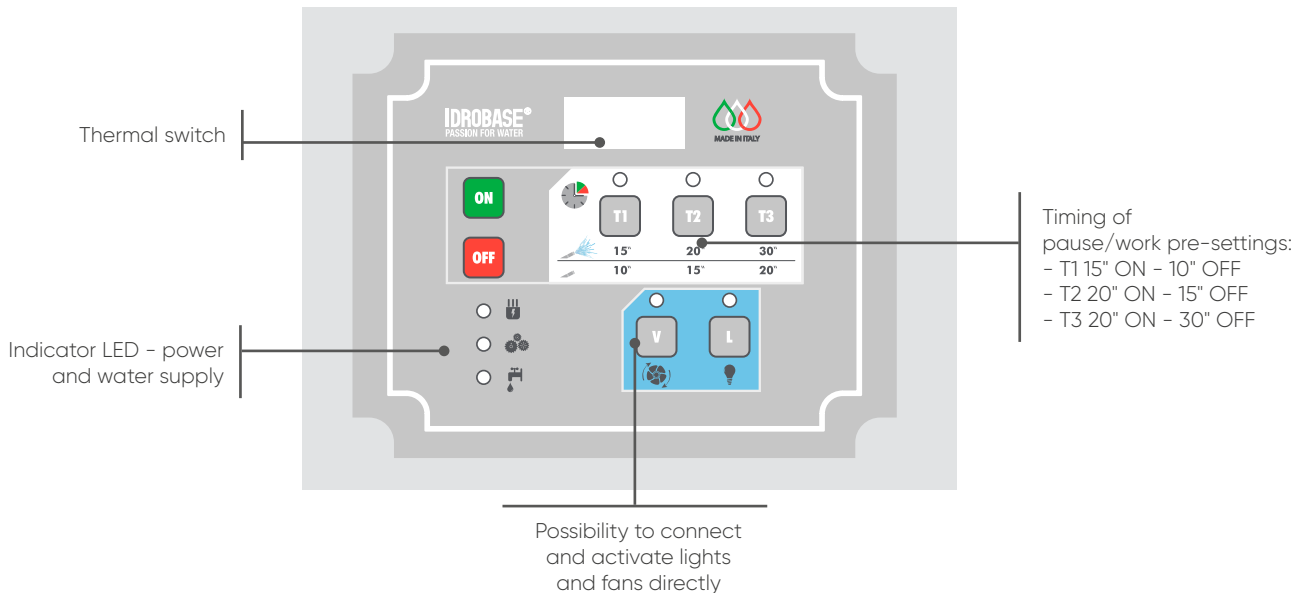

Technical features

- **Frame** made of painted steel
- **Axial motor pump with two ceramic pistons** 0.5 and 1l/min complete with by-pass valve
- **Electric control panel - with three time pre-settings**(with the option to directly operate the fans)
- **Solenoid valve- low pressure water inlet**
- **Solenoid valve** high pressure for pressure discharge
- **Pressure switch- low pressure no water supply**
- **Control panel** complete with: ON/OFF thermal cutout switch, continuous work mode or with 3 pause/work settings. Preset for connecting external devices (level sensor, fans, UV lamp, lights)
- **Four-channel radio remote control:** pump on/off, lights on/off, combined pump and fans on/off
- **Slip-lock inlet** ø9.6mm
- **Outlet, Slip-Lock** ø6.35mm
- **Dimensions LxDxH:** 450 x 300 x 280mm

FOG Extra

Fog module 60bar
230V-50Hz



Fog Extra to cool, humidify, suppress dust and odours and many more



Water inlet filter as standard, with 80micron AISI 304 stainless steel mesh. Works in conjunction with IT.0581 water supply Kit

Compact and versatile

The most **compact** and **versatile** solution to cool, create fog effects, humidify, suppress dust and odours in small and medium sized areas. Wide variety of **accessories** and types of line **matchable as required** for use in a wide range of applications.

The new control panel allows for quick and accurate setting of the work times and management of the connected optional probes.

SECURITY SYSTEM ANTI-FLOODING:

in the event of pipe breaks on the fog nozzle lines, the system automatically shuts down to prevent flooding in the areas where the lines are installed



Slip-Lock connectors for water inlet $\varnothing 9.6\text{mm}$ and water outlet $\varnothing 6.35\text{mm}$. Outside air intake for motor pump unit cooling



Pump with brass head (for the ZX.FL-2 version with 2l/min capacity)



Electrical connections for humidity ZX.SU20 and temperature ZX.ST20 probes

Axial pump with 2 pistons

Code	Model	*No. of nozzles	Max pressure	Flow rate	Power	Weight
ZX.FL-05	Fog Extra-05	10	60bar	0,5l/min	125W (1x230V-50Hz)	15kg
ZX.FL-1	Fog Extra-1	20	60bar	1l/min	200W (1x230V-50Hz)	15kg

Axial pump with 2 ceramic pistons, head in nickel-plated brass, integrated bypass valve, electric motor 1350rpm,

Axial pump with 3 pistons

Code	Model	*No. of nozzles	Max pressure	Flow rate	Power	Weight
ZX.FL-2	Fog Extra-2	40	60bar	2l/min	720W (1x230V-50Hz)	30kg





Axial motor pump with three ceramic-coated steel pistons, brass head, integrated by-pass valve, electric motor 1450rpm.

* The max number of nozzles has been calculated by using a nozzle with flow rate factor 15 (0.047l/min) at 60bar

FOG EXTRA is compatible with:

Linea kit	ZX.KL10, ZX.KL20, ZX.KL30 and ZX.KL40
Kit Vento	ZX.KV2-20, ZX.KV4-20, ZX.KV2-18, ZX.KV4-18, ZX.KV2-360, ZX.KV4-360, and ZX.KV2-P

Recommended accessories

	IT.0581	Water supply kit complete with mesh filter, and Fog module 3m water connection pipe		ZX.ST20	Humidity probe (for standard thermostat), with 20m cable
	IT.0582	Anti-limescale filter with polyphosphate salts for water supply kit		ZX.SU20	Humidity probe 4:20 mA (for standard humidstat), with 20m cable

Fog Extra Controls

- Humidstat **standard**
- Thermostat **standard**
- Display interface
- Cyclical ON/OFF timer
- Weekly time slot programmer
- Hour counter and maintenance schedule
- Pre-setting for connection of 230V ventilation systems
- Pre-setting for remote connection

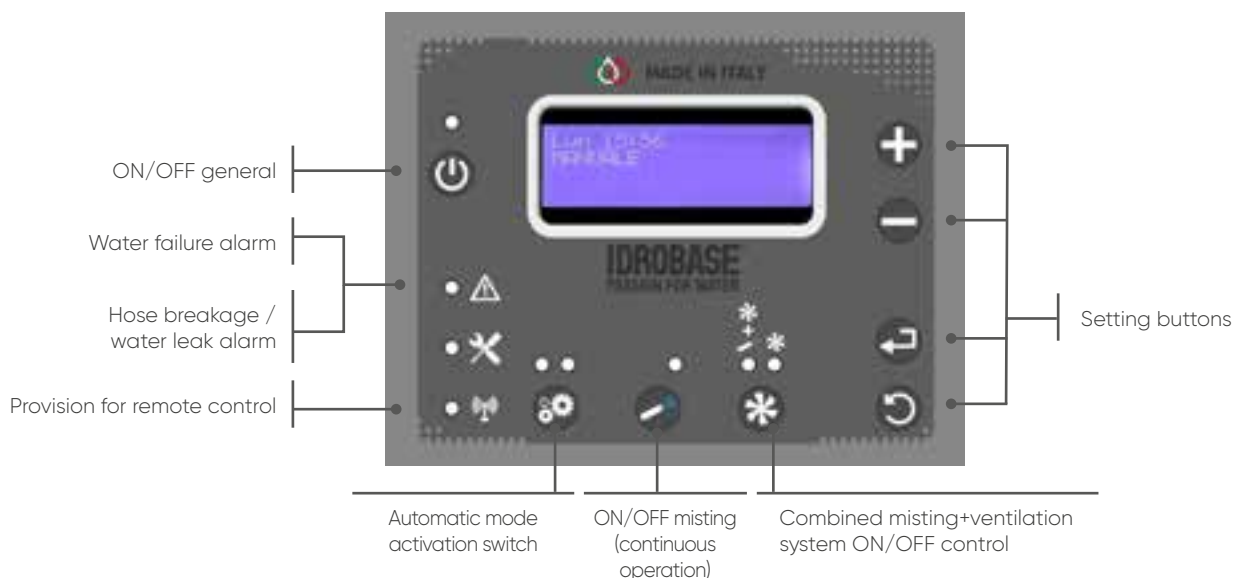

Technical features

- **Frame** made of painted steel
- **Unloader valve**
- **LP solenoid valve** 230V-50Hz, inlet water
- **H.p. solenoid valve** 230V-50Hz, to discharge line pressure
- **Electrical panel** complete with: ON/OFF thermal cutout, electronic board for management of anti-drip and timer system
- **Slip-lock inlet** $\varnothing 9.6\text{mm}$
- **Outlet, Slip-Lock** $\varnothing 6.35\text{mm}$
- **H. p. switch** for no water supply and pipe breaks
- **Dimensions WxLxH:** 600 x 300 x 300mm

Palma Rinfrescante

Refreshing accessory with 304 stainless steel structure complete with 6 pre-drilled pipes, connection fittings and 24 fog nozzles with 0.15mm holes with anti-drip system.

With buried connections and ground fixing of the structure.

Straightforward, quick installation, no special tools required.

The pipe junction connectors are made of AISI 304 SS and are equipped with compression fitting and a Slip-Lock connector to accommodate a high pressure polyamide pipe (max 60bar) $\varnothing 9.6 \times 5 \text{ mm}$. They must be connected to a nebulisation system

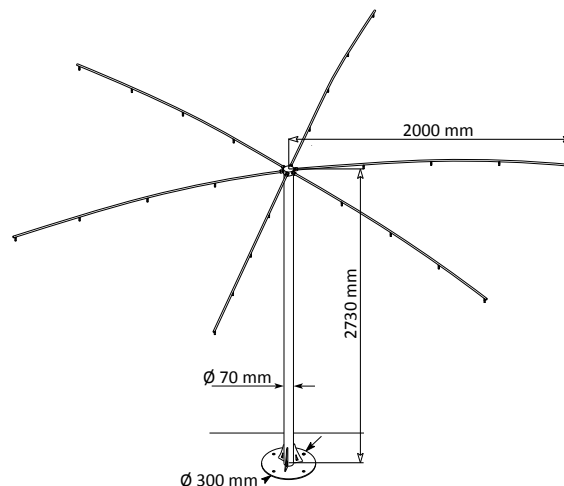

Model

Operating pressure

Water requirement at 60bars

Dimensions
L x W x H

ZX.6000

Palma Rinfrescante

60bar

2l/min

2000 x 2000 x 2730mm

Parasole Rinfrescante

Refreshing accessory with 304 stainless steel structure complete with 3 pre-drilled pipes, wall fixing bracket, connection fittings and 12 fog nozzles with 0.15mm holes with anti-drip system.

Straightforward, quick installation, no special tools required.

The pipe junction connectors are made of AISI 304 SS and are equipped with compression fitting and a Slip-Lock connector to contain a high pressure polyamide pipe (max 60bar) $\varnothing 9.6 \times 5 \text{ mm}$. They must be connected to a nebulisation system

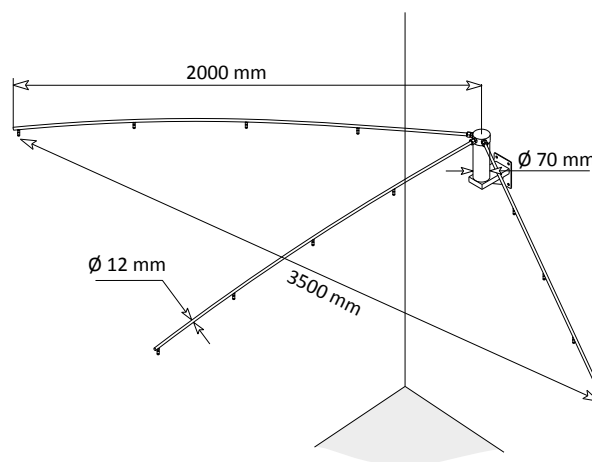

Model

Operating pressure

Water requirement at 60bars

Dimensions
L x W

ZX.6001

Parasole Rinfrescante

60bar

0,5l/min

2000 x 2000mm

Stelo Rinfrescante

Refreshing accessory with pre-drilled 304 stainless steel structure, complete with 10 fog nozzles with 0.15mm holes with anti-drip system.

With buried connections and ground fixing of the structure.

Straightforward, quick installation, no special tools required.

The pipe junction connectors are made of AISI 304 SS and are equipped with compression fitting and a Slip-Lock connector to accommodate a high pressure polyamide pipe (max 60bar) $\varnothing 9.6 \times 5$ mm. They must be connected to a nebulisation system

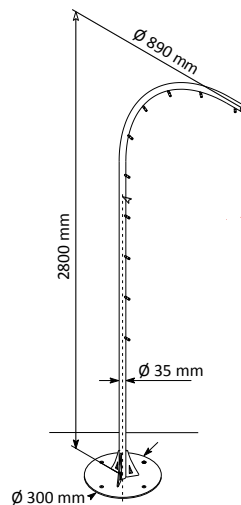

Model	Operating pressure	Water requirement at 60bars	Dimensions L x W x H
ZX.6002 Stelo Rinfrescante	60bar	0,5l/min	890 x 890 x 2800mm

Choose your refreshing accessory

Pumping modules

Fog App



Fog Eco Pro



Fog Extra



Code	Description	*No. of nozzles	ZX.FA10	ZX.FA15	ZX.5095-RC	ZX.5090-RC	ZX.FL-05	ZX.FL-1	ZX.FL-2
ZX.6000	Palma Rinfrescante	24							•
ZX.6001	Parasole Rinfrescante	18	•			•		•	
ZX.6002	Stelo Rinfrescante	10	•		•		•		